



CEN/TC 281 **N36**

(December 2003)

prEN 1860-2

For formal vote

For comments until 2004-01-22

(only editorial)

Document type: European Standard
Document subtype:
Document stage: Formal Vote
Document language: E

CEN /TC 281

Date: 2003-10

prEN 1860-2

CEN /TC 281

Secretariat: AENOR

**Appliances, solid fuels and firelighters for barbecuing — — Part 2:
Barbecue charcoal and barbecue charcoal briquettes. Requirements and
test methods**

Geräte, feste Brennstoffe und Anzündhilfen zum Grillen — — — — —

Appareils, combustibles solides et allume-barbecue pour la cuisson au barbecue — — — — —

ICS: 75.160.10

Descriptors:

Contents

Page

Foreword	5
Introduction.....	5
1 Scope	5
2 Normative references	5
3 Definitions	6
4 Requirements	7
4.1 General	7
4.2 Requirements for barbecue charcoal	7
4.2.1 Fixed carbon.....	7
4.2.2 Ash.....	7
4.2.3 Total moisture	8
4.2.4 Granulation.....	8
4.2.5 Volatiles	8
4.2.6 Bulk density.....	8
4.3 Requirements for barbecue charcoal briquettes	8
4.3.1 Fixed carbon.....	8
4.3.2 Ash.....	8
4.3.3 Moisture	8
4.3.4 Granulation.....	8
4.3.5 Binder	8
4.4 Inadmissible additions	8
4.4.1 Microscopic analysis	8
4.4.2 Chemical burning sustainers.....	9
5 Sampling.....	9
5.1 Sampling for granulometry	9
5.2 Sampling for testing ash, moisture, volatile and microscopic analyses	9
5.2.1 Preparation	9
5.2.2 Materials for use in the quartering method	9
5.2.3 Quartering method	9
6 Test methods.....	10
6.1 Moisture	10
6.1.1 Principle.....	10
6.1.2 Apparatus	10
6.1.3 Sample	10
6.1.4 Procedure	10
6.1.5 Expression of results	10
6.1.6 Precision of the method.....	11
6.2 Volatiles	11
6.2.1 Principle.....	11
6.2.2 Reagents.....	11
6.2.3 Apparatus	12
6.2.4 Preparation of sample.....	13

Document type: European Standard

Document subtype:

Document stage: Formal Vote

Document language: E

6.2.5	Procedure	15
6.2.6	Expression of results	15
6.2.7	Precision of the method.....	16
6.2.8	Impregnated products.....	16
6.3	Ash.....	16
6.3.1	Principle.....	16
6.3.2	Apparatus	16
6.3.3	Preparation of sample	17
6.3.4	Procedure	17
6.3.5	Expression of results	17
6.3.6	Precision of the method.....	18
6.3.7	Impregnated product.....	18
6.4	Fixed carbon.....	18
6.5	Test for inadmissible additions	18
6.6	Granulometry.....	19
6.7	Determination of impregnant content	19
6.8	Test report	19
7	Marking	19
7.1	19
7.2	20
7.2.1	20
7.2.2	20
Annex A	(normative) Determination of the volume of charcoal	22
A.1	General	22
A.2	Principle.....	22
A.3	Appliances.....	22
A.4	Sampling.....	22
A.5	Method of operation	22
A.6	Certificate of conformity	22
A.7	Inspection certificate.....	22
Annex B	(normative) Determination of moisture content for impregnated charcoal and for impregnated charcoal briquettes	24
B.1	General	24
B.2	Principle.....	24
B.3	Reagents.....	24
B.4	Apparatus	24
B.5	Preparation of sample	25
B.6	Procedure	26
B.7	Expression of results	26
B.8	Precision of the method.....	27
B.9	Test report	28

Foreword

This document has been prepared by CEN /TC 281, "Appliances, solid fuels and firelighters for barbecuing".

This document is currently submitted to the Formal Vote.

This document has to be implemented at national level, either by publication of an identical text or by endorsement, by **month year**, and conflicting national standards have to be withdrawn by **month year**.

This European Standard on *appliances, solid fuels and firelighters for barbecuing* consists of the following parts:

Part 1: Barbecues burning solid fuels - Requirements and test methods.

Part 2: Barbecue charcoal and barbecue charcoal briquettes. Requirements and test methods.

Part 3 : Firelighters for igniting solid fuels for use in barbecue appliances - Requirements and test methods.

Part 4: Single use barbecues burning solid fuels. Requirements and test methods.

According to the CEN/CENELEC Internal Regulations, the national standards organizations of the following countries are bound to implement this document:

Introduction

This standard is part 2 of the European Standard for appliances, solid fuels and firelighters for barbecuing, which is intended to reduce the risks which can occur during and trough barbecuing with solid fuels.

1 Scope

This European Standard specifies the requirements and test methods for charcoal and charcoal briquettes for use in BBQ appliances.

2 Normative references

This European Standard incorporates by dated or undated reference, provisions from other publications. These normative references are cited at the appropriate places in the text and the publications are listed hereafter. For dated references, subsequent amendments to or revisions of any of these publications apply to this European Standard only when incorporated in it by amendment or revision. For undated references the latest edition of the publication referred to applies (including amendments).

Document type: European Standard

Document subtype:

Document stage: Formal Vote

Document language: E

ISO 562, *Hard coal and coke — Determination of volatile matter*

ISO 579, *Coke — Determination of total moisture*

ISO 975, *Brown coals and lignites — Determination of yield of benzene-soluble extract — Semi-automatic method*

ISO 1171, *Solid mineral fuels — Determination of ash*

ISO 1953, *Hard coal — Size analysis by sieving*

ISO 1988, *Hard coal — Sampling*

ISO 5069-2:1983, *Brown coals and lignites - Principles of sampling —Part 2: Sample preparation for determination of moisture content and for general analysis.*

ISO 7404-2, *Methods for the petrographic analysis of bituminous coal and anthracite —Part 2: Preparation of coal samples*

ISO 7404-3, *Methods for the petrographic analysis of bituminous coal and anthracite — Part 3: Method of determining maceral group composition*

3 Definitions

For the purposes of this European Standard, the following terms and definitions apply

3.1

barbecue charcoal

solid remainder of carbonization of wood or other vegetable matter that does not spit/spark abnormally when burning and has not been artificially chemically treated or artificially chemically prepared whereby the main constituent is carbon and the ash content is minimal

3.2

barbecue charcoal briquette

barbecue charcoal briquettes are produced by compressing barbecue charcoal particles together with a suitable binder

3.3

impregnated barbecue charcoal and impregnated barbecue charcoal briquette

barbecue charcoal and barbecue charcoal briquettes prepared for lighting by addition of a lighting agent

3.4

fixed carbon

carbon remaining after the removal of volatile carbon matter and ash from dry charcoal

3.5

volatile matter

determined as the loss in mass less that due to moisture, when charcoal or charcoal briquettes is heated out of contact with air under standardised conditions

3.6

ash

residue after charcoal or charcoal briquettes are incinerated in air

3.7

total moisture

3.7.1

total moisture of barbecue charcoal and barbecue charcoal briquettes

water contained in the barbecue charcoal and the barbecue charcoal briquettes which is driven off at 105°C

3.7.2

total moisture of impregnated barbecue charcoal and impregnated barbecue charcoal briquettes

water contained in the impregnated barbecue charcoal and the impregnated barbecue charcoal briquettes which is removed by distillation with toluene

3.8

granulation

percentage by weight of charcoal which has been screened between two specific sizes

3.9

binder

product which when added to charcoal granules holds the particles together in a permanent solid mass

3.10

chemical sustainers

chemicals such as nitrates and nitrites added as oxidising agents to sustain burning

3.11

repeatability

results of duplicate determinations, carried out at different times in the same laboratory by the same operator using the same apparatus on duplicate samples taken from the same gross sample at the last stage of sample preparation, should not differ by more than the values indicated in 6.1.6, 6.2.6 and 6.3.6

3.12

reproducibility

means of the results of duplicate determinations, carried out in each of two different laboratories on representative portions taken from the same gross sample at the final stage of sample preparation, should not differ by more than the values indicated in 6.1.6, 6.2.6 and 6.3.6

4 Requirements

4.1 General

Impregnated barbecue charcoal and impregnated barbecue charcoal briquettes shall fulfil the requirements for barbecue charcoal and barbecue charcoal briquettes together with the requirements of EN 1860-3.

4.2 Requirements for barbecue charcoal

4.2.1 Fixed carbon

The fixed carbon in the dry charcoal shall be minimum of 75% by mass, calculated in accordance with 6.4.

4.2.2 Ash

The ash content in the dry charcoal shall not exceed 8%, when tested according 6.3.

Document type: European Standard

Document subtype:

Document stage: Formal Vote

Document language: E

4.2.3 Total moisture

The total moisture content shall not exceed 8%, when tested according 6.1.

4.2.4 Granulation

The particle size for the barbecue charcoal shall be 0 mm to 150 mm:

- No more than 10% may exceed 80 mm in size.
- At least 80% shall be greater than 20 mm.
- 0 mm- 10 mm shall not exceed 7%.

testing in accordance with 6.6.

4.2.5 Volatiles

The volatiles must be carried out to allow determination of fixed carbon but no limits are set as maximum or minimum.

4.2.6 Bulk density

The bulk density must be at least 130 kg/m³.

4.3 Requirements for barbecue charcoal briquettes

4.3.1 Fixed carbon

The fixed carbon of dry barbecue charcoal briquettes shall be minimum 60%, calculated in accordance with 6.4.

4.3.2 Ash

The ash content of dry barbecue charcoal briquettes shall be maximum 18%, when tested in accordance with 6.3

4.3.3 Moisture

The moisture content of barbecue charcoal briquettes shall not be above 8%, when tested in accordance with 6.1.

4.3.4 Granulation

The form and size of barbecue charcoal briquettes shall be suitable for use with barbecue equipment complying with EN 1860- 1. The granules less than 20 mm shall not exceed 10%, when tested in accordance with 6.6.

4.3.5 Binder

The binder must cause no health hazards when its combustion gases come into contact with food and the binder itself must be food grade quality.

4.4 Inadmissible additions

4.4.1 Microscopic analysis

Microscopic analysis in accordance with 6.5 should not detect more than 10 particles in 1 000 particles of any substance which is not normally found after the distillation of wood to produce wood charcoal or in permissible binder in wood charcoal briquettes.

The following inclusions are examples of inadmissible substances.

Organic : such as all fossil coals and derivatives thereof, petroleum, coke, pitch, plastic, etc.

Inorganic : such as glass, slag, rust, splinters of metal, stone powder, etc.

The total of all detected inadmissible additions should not exceed 1% by volume, when tested in accordance with 6.5.

4.4.2 Chemical burning sustainers shall not be permitted.

5 Sampling

5.1 Sampling for granulometry

The granulation test must be carried out using randomly selected bags on general sale using a minimum total sample weight of 40 kg.

Take the whole of each package and combine it to form the sample for granulometry analysis.

5.2 Sampling for testing ash, moisture, volatile and microscopic analyses

5.2.1 Preparation

Take the whole of the sample used to test granulometry and crush until 100% of the whole sample is less than 20 mm.

The samples for individual analysis are obtained from this < 20 mm sample by the quartering method.

5.2.2 Materials for use in the quartering method

A suitable sized sheet of glazed paper or plastic.

A cardboard or wooden board of suitable dimensions.

5.2.3 Quartering method

Place a clean dry sheet on the floor or alternatively in a box of suitable dimensions if preferred.

Pour the complete < 20 mm sample onto the sheet or in the box to form a cone or pyramid.

Divide the cone or pyramid into four parts in two operations using a cardboard or wooden board. The height and width of the board used must be greater than the height and width of the cone or pyramid formed by the sample on the sheet.

Select one of the four parts and repeat the process until approximately a 2 kg sample remains.

Take two of the final quarters, i.e. 2 x approximately 500 g samples, and seal in airtight jars for moisture testing.

Take a further quarter (approximately 500 g) for ash, volatile and microscopic analysis.

Take the final quarter for volatile testing and seal in an airtight jar and retain as a reference sample.

Document type: European Standard

Document subtype:

Document stage: Formal Vote

Document language: E

This whole process of granulometry testing, reducing sample to < 20 mm and subsequent quartering procedure must be undertaken at one time and as quickly as possible in order to minimise possible moisture loss from the bulk sample.

6 Test methods

6.1 Moisture

6.1.1 Principle

By modifying ISO 579 a sample is heated in air at 105°C - 110°C and maintained at this temperature until constant mass is obtained. The percentage moisture content is calculated from the loss in mass of the sample. Charcoal and charcoal briquettes are not liable to significant oxidation under the conditions stated.

For impregnated charcoal and impregnated charcoal briquettes the impregnant must be extracted before carrying out the test. The moisture test shall be done in accordance with annex B.

6.1.2 Apparatus

6.1.2.1 Air oven capable of maintaining a substantially uniform temperature zone at 105° C - 110°C and in which the rate of atmosphere change is sufficiently rapid for the test.

6.1.2.2 Tray approximately 0,1 m² in area and 25 mm deep made of non-corrodible material such as stainless steel, tinned steel or aluminium.

6.1.2.3 Balance accurate to 1 g.

6.1.3 Sample

The sample shall consist of 500 g of charcoal or charcoal briquettes prepared in accordance with the rules prescribed in sampling.

6.1.4 Procedure

Weigh, top the nearest 0,1%, the sample and container as received. Weigh the dry, empty tray, transfer the sample as completely as possible to the tray and spread evenly. Place the charged tray in the oven at the temperature of 105°C - 110°C. Dry the wet container with any sample adhering to it by warming, transfer the remaining sample to the tray and weigh the dry, empty container. Heat the tray and its contents until constant mass is obtained, weighing the tray hot to avoid absorption of moisture during cooling.

6.1.5 Expression of results

The moisture content M of the charcoal as analysed, expressed as a percentage by mass, is given by the formula.

$$M = \frac{(m_1 - m_4) - (m_3 - m_2)}{(m_1 - m_4)} \times 100$$

where

M is the moisture content, in percentage;

m_1 is the mass of the container plus sample as received, in grams;

m_2 is the mass of the dry, empty tray, in grams;

m_3 is the mass of the tray plus sample after heating, in grams;

m_4 is the mass of the dry, empty container, in grams;

The result, preferably the mean of duplicate determinations, shall be reported to the nearest 0,1%.

6.1.6 Precision of the method

Table 1 — Precision of the method

Total moisture content	Maximum acceptable differences Between results obtained	
	In the same laboratory (Repeatability)	In different laboratories (Reproducibility)
	0,5% absolute	0,7% absolute

6.2 Volatiles

The test is empirical and, in order to ensure reproducible results, it is essential that the rate of heating, the final temperature and the overall duration of the test shall be carefully controlled. The moisture content of the sample shall be determined at the same time as the volatile matter content so that the appropriate correction can be made.

The apparatus and procedure are so specified that one or more determinations may be carried out simultaneously in the muffle furnace.

6.2.1 Principle

By modifying ISO 562 the sample is heated at 900° C out of contact with air for 7 min. The percentage of volatile matter is calculated from the loss in mass of the sample after deducting the loss in mass due to moisture.

For impregnated charcoal and impregnated charcoal briquettes the impregnant must be extracted before carrying out the test.

6.2.2 Reagents

Desiccant, fresh or freshly regenerated and preferably self indicating. Suitable desiccants are silica gel, activated alumina and anhydrous calcium sulphate.

Document type: European Standard

Document subtype:

Document stage: Formal Vote

Document language: E

6.2.3 Apparatus

6.2.3.1 Muffle furnace, heated by electricity, in which an adequate zone at a constant and uniform temperature of (900 ±10) °C can be maintained. It may be of the stop-ended type or fitted at the back with a flue approximately 25 mm diameter and 150 mm long.

Its heat capacity shall be such that, with an initial temperature of 900°C, a minimum temperature of 885° C is regained within 4 min, preferably within 3 min, of the insertion of a cold stand and its crucible(s), the temperature being measured with an unsheathed thermocouple, as described in 6.2.3.2. Normally the furnace will be designed specifically either for receiving one crucible and its stand or for multiple determinations using a number of crucibles in one stand.

The temperature of 900°C shall be attained as closely as possible and the tolerance of ± 10° C is specified so as to meet inherent errors in the temperature measurement and lack of uniformity in the temperature distribution.

A position for the crucible stand shall be chosen within the zone of uniform temperature and this position used for all determinations.

6.2.3.2 Pyrometer

The temperature characteristics of the furnace shall be checked with an unsheathed thermocouple, of wire not thicker than 1 mm. The thermojunction shall be inserted midway between the base of the crucible in its stand and the floor of the furnace. If the stand holds more than one crucible, then the temperature under each crucible shall be checked in the same manner. If desired, a sheathed thermocouple may be permanently installed in the furnace with its thermojunction as close as possible to the centre of the zone of uniform temperature; in this case, its temperature readings shall be correlated at frequent intervals with those of the unsheathed thermocouple, which is then inserted only when necessary.

NOTE The temperature/electromotive force relationship of a thermojunction maintained at elevated temperatures gradually changes with time.

6.2.3.3 Crucible and lid

A cylindrical crucible with a well fitting lid, both of fused silica. The crucible and lid shall have a mass between 10 g and 14 g and dimensions approximating to those shown in Figure 1. The fit of the lid on the crucible is critical to the determination and a lid shall be selected to match the crucible so that the horizontal clearance between them is not greater than 0,5 mm. After selection, the crucible and the lid shall be ground together to give smooth surfaces and then be given a common distinguishing mark.

Dimensions in millimetres

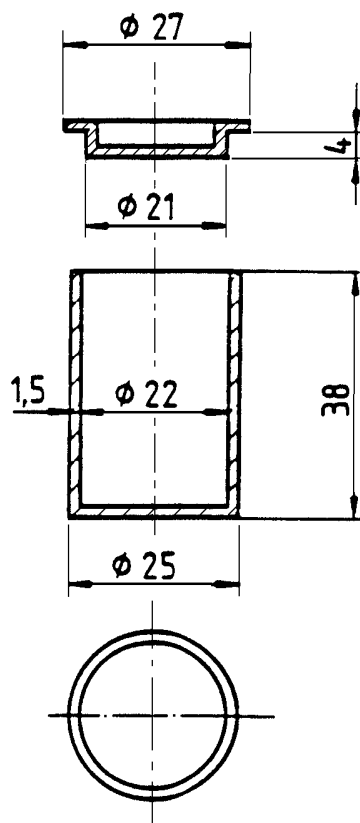

Figure 1 — Silica crucible and lid crucible made of silica must be used.

6.2.3.4 Stand

On which the crucible is placed in the muffle furnace, such that the appropriate rate of heating can be achieved. For example, it may consist of the following:

- a) for single determination: a ring of heat-resistant steel wire as shown in figure 2, with two suitable refractory material disks, 25 mm diameter and 1 mm thick, resting on the inner projection of its legs; or
- b) for multiple determinations: a tray of heat-resistant steel wire as shown in Figure 3, of appropriate size, with a suitable refractory material plat 2 mm thick supporting the crucible.

6.2.3.5 Balance, accurate to 0,1 mg

6.2.4 Preparation of sample

The charcoal used for the determination of volatile matter is the analysis sample ground to pass a sieve of 212 μm aperture.

Document type: European Standard

Document subtype:

Document stage: Formal Vote

Document language: E

Before commencing the determination, mix the analysis sample thoroughly for at least 1 min, preferably by mechanical means.

Dimensions in millimetres

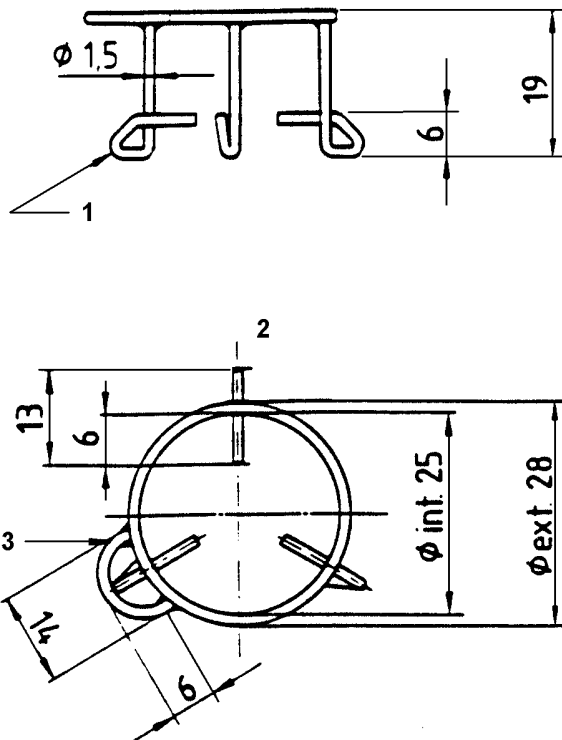

Key

- 1 Three legs spaced at 120° apart
- 2 Ring
- 3 Handle

Figure 2 — Crucible stand for a single determination

Dimensions in millimetres

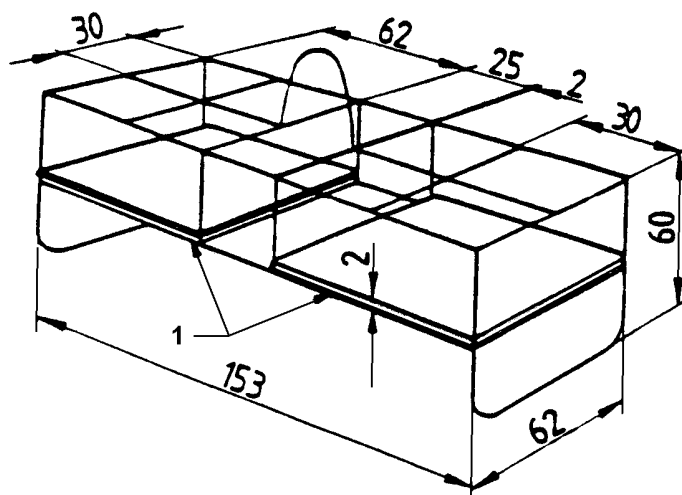

Key

- 1 Suitable refractory material sheets

Figure 3 — Crucible stand for multiple determinations

6.2.5 Procedure

Heat in the muffle furnace at $(900 \pm 10)^\circ\text{C}$ for 7 min either on crucible and lid or the requisite number of crucibles and lids to fill the multiple stand. Remove from the furnace, allow the crucible(s) to cool first on a metal slab and finally in a desiccator located next to the balance.

- As soon as these are cool, weigh each empty crucible and lid and weigh into each crucible, to the nearest 0,1 mg, 1,00 g to 1,01 g of sample. As we must express the results on a dry basis the following initial action is taken:
- Heat the crucible without the lid to 105°C - 110°C for 1 h.
- Cool in a desiccator.
- Reweigh the crucible and dried charcoal powder and calculate the exact weight of dried charcoal remaining in the crucible to be tested for volatile content.
- Replace the lid and tap the crucible on a clean, hard surface until the sample forms a layer of even thickness on the bottom of the crucible.

Precisely similar treatment of the crucible before and after the determination minimises the effect of any film of water absorbed on its surface, while the rapid cooling reduces absorption of moisture by the charcoal residue.

- Adjust the temperature of the zone in the muffle furnace to $900^\circ\text{C} \pm 10^\circ\text{C}$.
- Place the charged crucibles in a cold stand and transfer to the furnace. Close the door and allow to remain for exactly 7 min. Remove, cool in a desiccator and weigh the crucible(s) to establish m_3 as required to calculate and express the results.
- If multiple determinations are being made any vacant places in the stand should be filled with empty crucibles.

6.2.6 Expression of results

The volatile matter V on a dry basis expressed as a percentage by mass, is given by the equation

$$V = \frac{(m_2 - m_3)}{(m_2 - m_1)} \times 100$$

where

V is the volatile matter, as a percentage by mass, in the sample analysed;

m_1 is the mass of the empty crucible and lid, in grams;

m_2 is the mass of the crucible and lid and sample after drying at 105°C for 1 h, in grams;

m_3 is the mass of the crucible and lid and content after heating, in grams;

Document type: European Standard

Document subtype:

Document stage: Formal Vote

Document language: E

The results (preferably the mean of duplicate determinations) shall be reported to the nearest 0,1%.

6.2.7 Precision of the method

Table 2 — Precision of the method

Sample	Maximum acceptable differences	
	Between results obtained (calculated to the same moisture content)	
	In the same laboratory (Repeatability)	In different laboratories (Reproducibility)
Charcoal and charcoal briquettes of volatile matter Content > 10 %	0,3% absolute	0,5% absolute

6.2.8 Impregnated products

Before testing impregnated barbecue charcoal or impregnated barbecue charcoal briquettes the impregnant must be extracted according to 6.7

6.3 Ash

6.3.1 Principle

By modifying ISO 1171 the sample is heated in air at a specified rate up to a temperature of $(710 \pm 10)^\circ \text{C}$ and maintained at this temperature until constant in mass.

The percentage of ash is calculated from the mass of the residue after incineration.

For impregnated charcoal and impregnated charcoal briquettes the impregnant must be extracted before carrying out the test.

6.3.2 Apparatus

6.3.2.1 Balance, accurate to 0,1 mg

6.3.2.2 Muffle furnace capable of giving a zone of substantially uniform temperature at the levels required by the procedure and of reaching these levels in the specified times. The ventilation through the muffle furnace shall be such as to give above fine air changes per minute.

The number of air changes per minute can be assessed by the measurement of the air flow in the muffle furnace flue by means of a pitot-static tube and sensitive manometer.

6.3.2.3 Dish of silica, porcelain, or platinum, 10 mm to 15 mm deep, with lid. The diameter of the dish shall be such that the surface (mass) density of the sample layer does not exceed 0,15g/cm².

6.3.2.4 Insulating plate of silica, 6 mm thick, or its equivalent, of such size as to be an easy sliding fit into the muffle furnace.

6.3.3 Preparation of sample

The charcoal used for the determination of ash is the analysis sample ground to pass a sieve of 200 µm aperture.

Before commencing the determination, mix the analysis sample thorough for at least 1 min, preferably by mechanical means.

6.3.4 Procedure

NOTE If a silica dish is used, before its initial mass is determined, it shall be heated to (710 ± 10)° C, maintained at this temperature for 15 min and then cooled under the conditions specified for the actual determination.

Weigh to the nearest 0,1 mg, the clean, dry dish and lid (see the note) spread 1g to 2g of the sample evenly in the dish.

The results are expressed on a dry basis. Therefore the following initial action is taken:

- a) Heat the dish and sample at 105° C to 110°C for 1 h.
- b) Cool in a desiccator.
- c) Reweigh the dish and dried charcoal powder and calculate the exact weight of dried charcoal remaining in the dish to be tested for ash content.

Insert the uncovered dish in the muffle furnace at room temperature. Raise the temperature to 250°C in 30 min from 250°C to 500°C in a further 30 min; from 500°C to (710 ± 10)° C in a further 60 min and maintain until constant mass is achieved.

When incineration is complete cover the dish with its lid, remove the dish from the furnace, cover the dish with its lid, and allow to cool on a thick metal plate for 10 min and with optional subsequent transfer to a desiccator without desiccant.

When cool, weigh to the nearest 0,1 mg, the dish covered with its lid. Reheat at (710 ± 10)° C for a further 15 min period until any further change in mass does not exceed 1 mg.

6.3.5 Expression of results

The ash *A* of the sample as analysed, expressed as a percentage by mass, on a dry basis is given by the formula

$$A = \frac{(m_3 - m_1)}{(m_2 - m_1)} \times 100$$

where

A is the ash content in percentage;

Document type: European Standard

Document subtype:

Document stage: Formal Vote

Document language: E

m_1 is the mass of the dish plus lid, in grams;

m_2 is the mass of dish plus lid plus sample after drying at 105° C to 110°C for 1 h, in grams;

m_3 is the mass of dish plus lid plus ash, in grams.

The result (preferably the mean of duplicate determinations) shall be reported in accordance with 6.8 to the nearest 0,1%.

6.3.6 Precision of the method

Table 3 — Precision of the method

Ash	Maximum acceptable differences Between results obtained (calculated to the same moisture content)	
	In the same laboratory (Repeatability)	In different laboratories (Reproducibility)
Less than 10 %	0,2% absolute	0,3% absolute
10% and over	2,0 % of the mean result	3,0 % of the mean result

If the final crushing to pass a 200 µm sieve is carried out in different laboratories, the values for the reproducibility given above may be exceeded.

6.3.7 Impregnated product

Before testing impregnated barbecue charcoal or impregnated barbecue charcoal briquettes the impregnant must be extracted according to 6.7.

6.4 Fixed carbon

The percentage by weight of fixed carbon is mathematically calculated by the following equation.

$$C(\text{fix}) = 100 - (F + A)$$

F is the volatile matter content expressed as a percentage by weight of the water free material (WF)

A ash as a percentage by weight of water free material (WF)

6.5 Test for inadmissible additions

The sample must be ground in accordance with ISO 1988.

The crushed material is placed on a polished surface which has been prepared in accordance with ISO 7404-2. It is then examined for inadmissible additions under a microscope in accordance with ISO 7404-3

The investigation is carried out by means of reflected light using:

- a) normal white light;
- b) polarised light;
- c) blue light excitation;
- d) all at 300 x magnification.

The quantification of inadmissible additions is given as a percentage by volume (Vol %) and is carried out according to ISO 7403 with the following modifications :

- a minimum of 1 000 particles has to be counted disregarding particles in the mounting medium;
- the results of the counting are presented as a percentage by volume rounded to the nearest integer;
- before testing impregnated barbecue charcoal or impregnated barbecue charcoal briquettes the impregnant must be removed.

6.6 Granulometry

The sample is carefully sieved with round test sieves with a hole diameter of 150 mm, 80 mm, 20 mm and 10 mm, in accordance with ISO 1953. The respectively sieved amount is determined by weighing. The sieve is riddled until no further notable passing takes place. Stalky pieces longer than 150 mm may occur which can fall through the sieve in another direction. These pieces should be classified in the 20 - 80 fraction.

6.7 Determination of impregnant content

The impregnated barbecue charcoal or impregnated barbecue charcoal briquettes are to be extract with N-hexane in accordance with ISO 975 and percentage level of the extracted impregnant is to be determined with 4.1.1 of EN 1860-3 method.

6.8 Test report

The test report shall include the following particulars:

- a) an identification of the product tested;
- b) the results and the basis of analysis;
- c) an unusual features noted during the determination;
- d) deviation from this Standard.

7 Marking

7.1

The packaging of the charcoal and the charcoal briquettes to be sold should bear the following markings:

Document type: European Standard
Document subtype:
Document stage: Formal Vote
Document language: E

- a) Contents indication must be marked on the bag for both barbecue charcoal and barbecue charcoal briquettes and their impregnated versions. The content indication can be made either in weight or in volume according to National Law unless any subsequent EC Law supersedes it.
- b) "Barbecue Charcoal" or "Barbecue Charcoal Briquettes" will be the minimum marking/description of the contents.
- c) Instructions should specify considerations of safety, health and usage for the correct and safe use of the product.
- d) The number of this standard (the compliance with this Standard must be proved by a certified laboratory).

NOTE The test method for the determination of the volume of charcoal is submitted in annex A (normative).

7.2

7.2.1

The packaging of the impregnated charcoal and impregnated charcoal briquettes to be sold should bear the following markings if sold in a bag which should be used unopened:

- a) Do not open the bag.
- b) Put the bag in the barbecue.
- c) Light the corners of the bag.
- d) Do not put new bags on a barbecue once cooking food has commenced.
- e) Content, i.e. 4x1 kg, 1x1, 4 kg, 2x LT, etc.
- f) "WARNING: Do not put additional impregnated barbecue charcoal or impregnated barbecue charcoal briquettes onto a barbecue once cooking has commenced"
- g) Impregnated barbecue charcoal or impregnated barbecue charcoal briquettes will have a clear indication on the packaging that the product is impregnated.

WARNINGS:

- do not use indoors;
- keep children at a safe distance;
- do not expose bags to extreme temperatures;
- do not use an additional starting agent after the barbecue is lit.

7.2.2

The packaging of the impregnated charcoal and impregnated charcoal briquettes to be sold should bear the following markings if sold in a bag which contains loose product suitable for multiple barbecue use.

- a) Put sufficient impregnated BBQ charcoal or impregnated BBQ charcoal briquettes into the barbecue.
- b) Light the charcoal or charcoal briquettes.
- c) Do not add additional loose impregnated fuel onto a BBQ once cooking food has commenced.

WARNINGS:

- do not use indoors;
- keep children at a safe distance;
- do not expose bags to extreme temperatures;
- do not use an additional starting agent after the barbecue is lit.

Document type: European Standard
Document subtype:
Document stage: Formal Vote
Document language: E

Annex A (normative)

Determination of the volume of charcoal

A.1 General

This annex describes a method for determining the volume of charcoal contained in a bag whose contents are marked in litres. It applies to charcoal as specified in EN 1860-2.

A.2 Principle

A standardised container which corresponds with the volume marked on the bag is filled with charcoal. The free surface of the charcoal is levelled off using a ruler.

The difference between the volume of the contents in the bag and the volume of the container is evaluated by the average distance between the upper surface of the charcoal and the rule pressed onto the edge of the container.

A.3 Appliances

The container with a volume identical to the one marked on the bag has a cylindrical shape, is of rigid construction: the height and the internal diameter must be equal.

The levelling ruler must be rigid, straight, and with straight square or oblong cross-section.

A.4 Sampling

The inspections must be carried out on bags of merchantable quality, taken as samples directly from the points of sale.

A.5 Method of operation

Open the bag, slowly pour the charcoal into the inspection container. The pouring height must be as low as possible, as the bag opening is held at the height of the top of the container.

Once the bag is completely empty, leave-off the top of the heap of charcoal using a ruler which must be able to rest in any direction on the upper rims of the container.

A.6 Certificate of conformity

The contents of the bags are declared to be in conformity where the ruler touches the upper pieces of charcoal or if the distance between the ruler and the tops of the pieces of charcoal does not exceed one centimetre.

A.7 Inspection certificate

The certificate must show the inspection conditions:

- Place: The trade name and address of the point of sale from which the bag was sampled.

- Sales denomination of the product, packing code, name and address of the manufacturer or distributor.
- The volume of the bag.
- The volume of the container.
- Certificate of conformity or of non-conformity.
- The approved body which has carried out the inspection.

Document type: European Standard
Document subtype:
Document stage: Formal Vote
Document language: E

Annex B (normative)

Determination of moisture content for impregnated charcoal and for impregnated charcoal briquettes

B.1 General

This annex specifies a direct volumetric method of determining the moisture content of brown coals and lignites. It may be used for the determination of either total moisture or the moisture in the analysis sample.

B.2 Principle

A test portion is heated under reflux conditions in a flask containing boiling toluene or xylene. The moisture is entrained by the toluene or xylene vapour and carried to a condenser fitted with a graduated receiver. The water then separates in the receiver to form a lower layer while the excess reagent is returned to the distillation flask by means of an overflow. The moisture content is calculated from the mass of sample taken and the volume of water collected.

NOTE 1 The results obtained using toluene and xylene may not be identical for all brown coals and lignites. It is preferable to use toluene, as opposed to xylene, in cases where the latter may cause liberation of water from coal functional groups. Furthermore, to obtain moisture results comparable to alternative methods such as that described in ISO 5068:1983, *Brown coals and lignites - Determination of moisture content - Indirect gravimetric method*, it is advisable to employ toluene which boils in a range similar to the drying temperature specified in ISO 5068.

B.3 Reagents

During the analysis, use only reagents of recognized analytical grade, and distilled water or water of equivalent purity.

B.3.1 Toluene (see note 2), distillation point 110 °C.

or

B.3.2 Xylene (see note 2), distillation interval 135 °C to 140 °C.

WARNING — Xylene and toluene are flammable, and toxic by inhalation, ingestion or skin absorption.

NOTE 2 In view of the low solubility of water in either toluene or xylene, it can be shown that only a very small error in the determination could arise from variations in the condition of saturation of the entraining reagent. However, in order to reduce this error to insignificance, it is recommended that the reagent be used in the same condition for the determination as during calibration of the apparatus.

B.4 Apparatus

All graduated apparatus shall be of the best analytical quality available.

B.4.1 Distillation flask, of minimum capacity 500 ml.

B.4.2 Condenser, having a minimum length of water jacket of 200 mm, and fitted with an extended lip to direct the distillate into the receiver without touching the sides.

B.4.3 Receiver, for the condensed water, graduated in 0,1 ml.

It is important that the receiver and condenser be clean. To ensure this, they shall be treated with a cleansing reagent such as a strong solution of potassium dichromate in sulphuric acid.

The condenser, receiver and flask are fitted together by means of ground glass joints. An overflow tube connected to the receiver or to the lower portion of the condenser permits the return of condensed reagent to the distillation flask. The condenser may be fitted to condense either an upward-flowing or downward-flowing vapour stream.

B.4.4 Pieces of glass tubing, 5 mm in diameter and 5 mm long, with sharp edges, to be used as boiling aids.

B.4.5 Spray tube, of glass, through which the reagent can be supplied to wash down the inner surface of the condenser. This precaution is required only when an upward-flow condenser is employed.

B.4.6 Burette, graduated in 0,05 ml divisions.

B.4.7 Balance, accurate to 10 mg.

B.5 Preparation of sample

B.5.1 Prepare the sample for the determination of total moisture in accordance with ISO 5069-2:1983, clause 7.

NOTE 3 If the air-drying process has been carried out according to ISO 5069-2:1983, clause 9, the total moisture, M_T expressed as a percentage by mass, is calculated from the formula.

$$M_T = W_{ex} + M \left(1 - \frac{W_{ex}}{100}\right)$$

where

W_{ex} is the moisture loss due to air-drying, expressed as a percentage by mass;

M , is the percentage of residual moisture in the air-dried sample.

Document type: European Standard

Document subtype:

Document stage: Formal Vote

Document language: E

B.5.2 Prepare the sample for the determination of moisture in the analysis sample in accordance with ISO 5069-2:1983, clause 8.

B.6 Procedure

B.6.1 Calibration of apparatus

Calibrate each apparatus by distilling a series of accurately known volumes of water, measured using the burette, covering the range of moisture contents likely to be encountered in the samples to be tested.

Plot a graph, showing the volume in millilitres of water added against the scale reading of the water recovered in the receiver. Use the graph to correct the volume of water obtained in each test.

The calibration shall be repeated when there is any change of reagents or of any part of the apparatus.

B.6.2 Test portion

Before commencing the determination of moisture in the analysis sample, mix the air-dried sample thoroughly for at least 1 min, preferably by mechanical means.

Weigh, to the nearest 0,01 g, about 50 g of the sample (when the moisture content is expected to be above 20 % (*m/m*), weigh 25 g), and transfer to the dry distillation flask. Add 200 ml of the toluene or xylene in such a way that any sample adhering to the neck or side of the flask is washed down by the reagent.

NOTE 4 The mass of the test portion and the size of the receiver are interrelated. In general, the condensed water should occupy at least one-third of the graduated volume of the receiver.

B.6.3 Determination

Fill the receiver with the same reagent. Place two or three pieces of the glass tubing in the distillation flask to prevent violent ebullition and assemble the apparatus. Start the flow of water through the condenser and heat the flask uniformly and gently so that its contents begin to boil after about 15 min. Subsequently adjust the rate of heating to ensure a distillation rate of 2 to 4 drops per second.

Continue the distillation until the toluene or xylene reflux is clear and no further water collects in the receiver. If a condenser is used for an upwardflowing vapour steam, wash down any drops of water adhering to the inner surface of the condenser or to the upper walls of the receiver with the reagent employed using the spray tube, and continue the distillation for a sufficient time to ensure that any water washed back into the distillation flask has been carried over into the receiver. Allow the cloudiness of the distillate to clear and read the volume of water collected in the receiver.

B.7 Expression of results

Assuming that the density of the water is 1 g/ml, the moisture content, *M* of the analysed sample, expressed as a percentage by mass, is given by the formula

$$M = \frac{V_c}{m} \times 100$$

where

V_c is the corrected volume, in millilitres, of water read from the graph;

m is the mass, in grams, of the test portion.

The result obtained represents

- the percentage by mass of total moisture in the sample, if the latter has not been air-dried previously; or
- the percentage of residual moisture, if any air drying procedure has been included in the preparation of the sample; or
- the percentage of moisture in the analysis sample.

The final result shall be reported to the nearest 0,1 % (m/m).

B.8 Precision of the method

B.8.1 Repeatability

The maximum acceptable difference between single determinations carried out in one laboratory on two separate moisture samples taken simultaneously, in accordance with ISO 5069-2, shall not exceed the values given in table B.1.

B.8.2 Reproducibility

The maximum acceptable difference between single determinations carried out in different laboratories on two separate moisture samples taken simultaneously, in accordance with ISO 5069-2, shall not exceed the values given in table B.1.

Table B.1 — Precision data

Moisture content	Maximum acceptable differences between results	
	Repeatability	Reproducibility
Less than 20 % (m/m)	0,4 % (m/m)	0,8 % (m/m)
20 % (m/m) and over	2,0 % of result	4,0 % of result

B.9 Test report

The test report shall include the following particulars:

- a) the reference of the method used;
- b) the entraining reagent used and its degree of saturation (i.e. "wet" or "dry");
- c) the result and the method of expression used;
- d) any unusual features noted during the determination;
- e) any operation not included in this Standard or in the Standard to which a reference is made, or any optional operations.

Bibliography

- [1] ISO 5068: 1993, *Brown coals and lignites — Determination of moisture content — Indirect gravimetric method*